

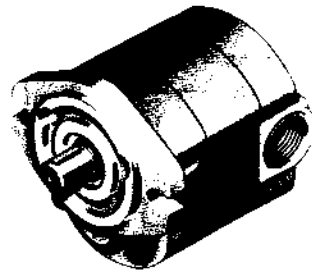

HYDRAULIC MOTORS

GEAR MOTORS 40 SERIES Specification Sheet

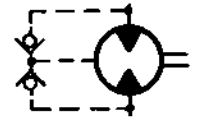

The CROSS series 40 hydraulic gear type motors feature advanced design concepts which produce long service life and high reliability when operated up to rated speeds and pressures. Improved gear tooth design and pressure-balanced loading plates provide for a high volumetric and overall efficiency, while operating at a low noise level.

GENERAL SPECIFICATIONS

Displacement sizes

0.50	0.75	1.00	1.25	1.50	1.80	cu.in./Rev.
8.2	12.3	16.4	20.5	24.6	29.5	cc/Rev.

- Rated working pressure (Max. relief valve setting at full flow) 3000 psi (207 bar)
- Maximum shock and surge pressure 3500 psi (242 bar)
- Maximum flow rate (input) 20.45 gpm (77.4 l/m)
- Maximum speed (continuous) up to 4000 rpm
- Maximum horsepower (at rated speed and pressure) 49 hp (36.5 Kw)
- Mounting (any position) SAE "A" size, 2-bolt
- Weight Approx. 7 lbs. (3.2 Kg)

MATERIAL SPECIFICATIONS

- Body and end covers Die cast aluminum alloy
- Gears Sintered metal
- Shaft Hardened steel
- Bearings Pressure lubricated, Teflon impregnated sleeve
- Seals Buna N

STANDARD FEATURES

- Rotation: Bi-directional (Dual Rotation)
- Ports: 3/4" SAE #12 straight thread o-ring (1 1/16 - 12) • 1/4" NPTF Drain port
- Internal check valves (no external drain required if back pressure is below shaft seal rating)
- Shaft: 5/8" dia. Woodruff keyed (short) • Shaft Seal: 250 psi (17 bar)

OPTIONAL FEATURES AVAILABLE

- Rotation: Right hand (clockwise); Left hand (counterclockwise)
- Ports: Rear inlet and outlet location
- Shafts: 5/8" dia. splined (9 tooth); 5/8" dia. keyed (long); 3/4" dia. keyed (short); 3/4" dia. keyed (long)

NOTE: Refer to CROSS pump and motor technical/service sheet for side and end load limitations, oil and filter recommendations, start-up procedures, etc.



DIMENSIONAL DATA in inches and (millimeters)

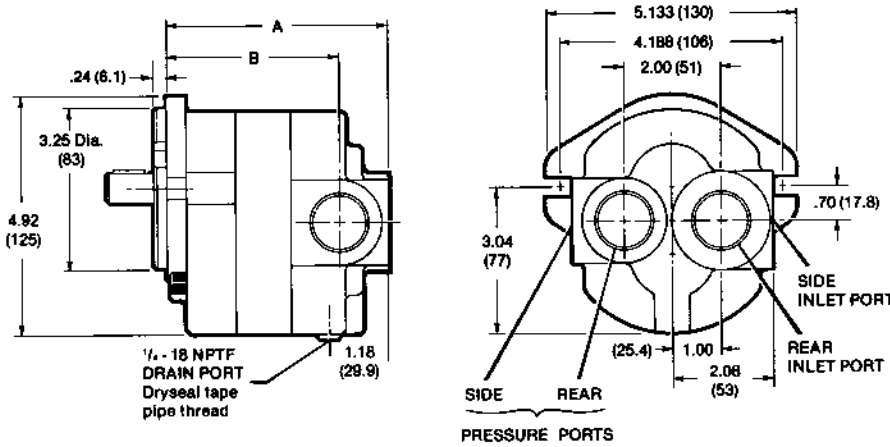

Displacement cu.in./Rev. (cc/Rev.)	Dim. "A" inches (mm)	Dim. "B" inches (mm)
.50 (8.2)	4.25 (107)	3.23 (82)
.75 (12.3)	4.44 (112)	3.42 (86)
1.00 (16.4)	4.62 (117)	3.60 (91)
1.25 (20.5)	4.81 (122)	3.79 (96)
1.50 (24.6)	4.99 (126)	3.97 (100)
1.80 (29.5)	5.22 (132)	4.20 (106)

OUTPUT SHAFT

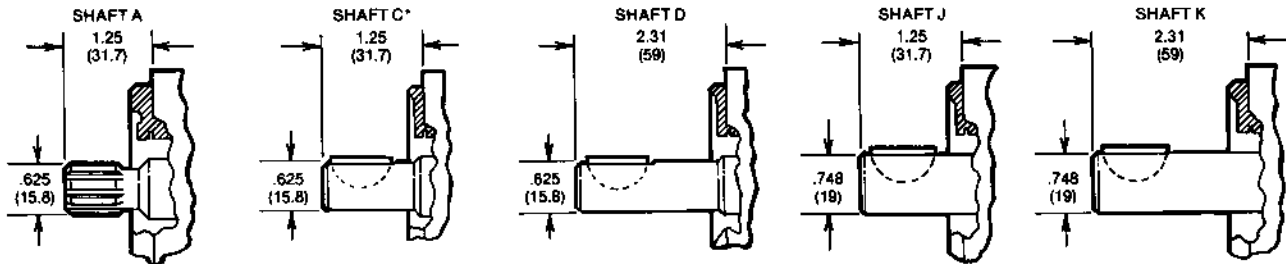

SHAFT "A": 9 tooth, 16/32 pitch, 30° pressure angle, flat root side fit, Class 1.
 SHAFT "C" and "D": Woodruff key - 5/16" dia. x 5/32.
 SHAFT "J" and "K": Woodruff key - 3/4" dia. x 5/32.

ORDERING DATA

Series	Type	Special Options	Size cu.in./R x 10	Rotation	Mounting	Shaft Size & Type		PORTS LOCATION and SIZE										
						A	J	Inlet	Outlet									
40	M motor	H 250 psi shaft seal	5	D dual	A SAE "A" 2-bolt	A 5/8" spline	J 3/4" dia. keyed	SC	1 1/16	1 1/16	SIDE PORTS							
			7															
			10															
			12									L left	C 5/8" dia. keyed	K 3/4" dia. keyed				
			15									R right	D 5/8" dia. keyed (long)	(long)	RD	1 1/16	1 1/16	REAR PORTS
			18															

EXAMPLE: 40MH12DACSC

Describes a Series 40 Gear Motor, 250 psi shaft seal, displacement of 1.2 cu. in. per revolution; bi-directional rotation; SAE "A" 2-Bolt Mount; 5/8" dia. keyed shaft and 1 1/16-12 side ports.



HYDRAULIC MOTORS

GEAR MOTORS 40 SERIES

TYPICAL PERFORMANCE DATA

(FOR SPECIFIC PERFORMANCE DATA,
CONTACT CROSS ENGINEERING)

MODEL 40M005

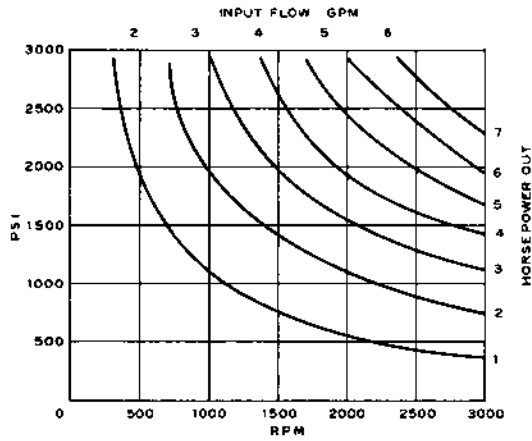

MODEL 40M012

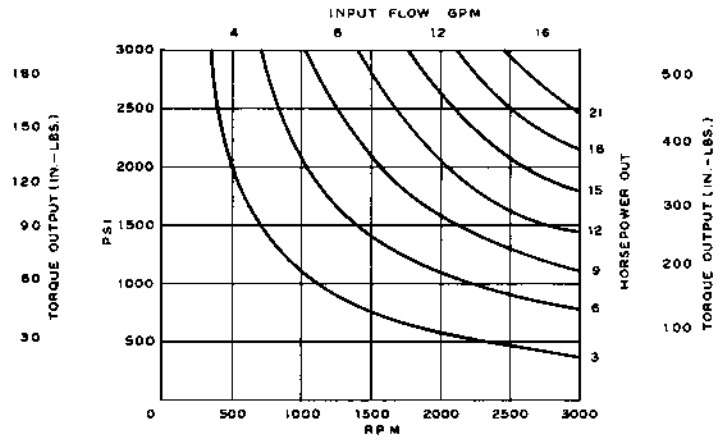

MODEL 40M007

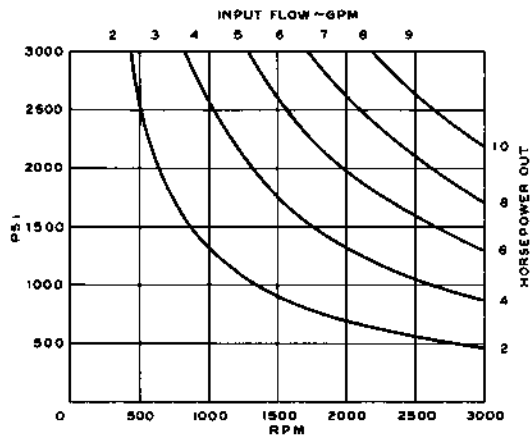

MODEL 40M015

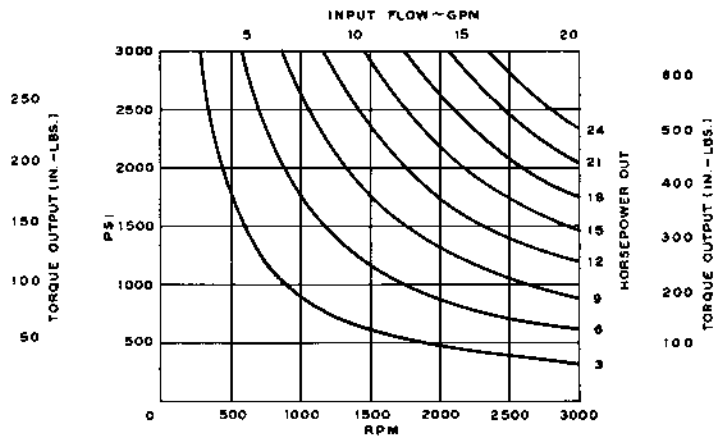

MODEL 40M010

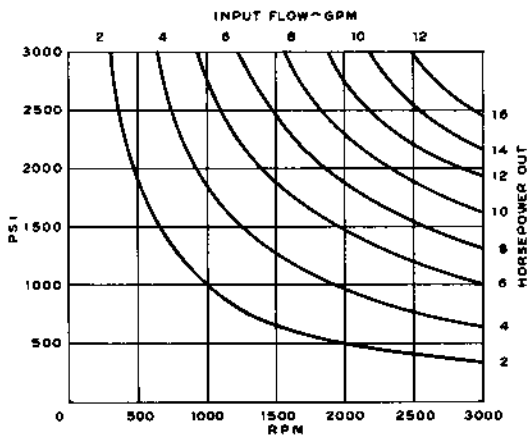

MODEL 40M018

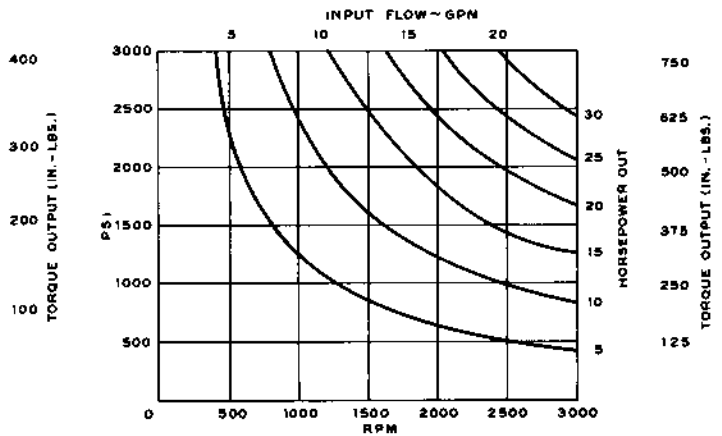



TYPICAL PERFORMANCE DATA

STARTING ENGINE TORQUE (in.-lbs.) vs. PRESSURE (PSI)

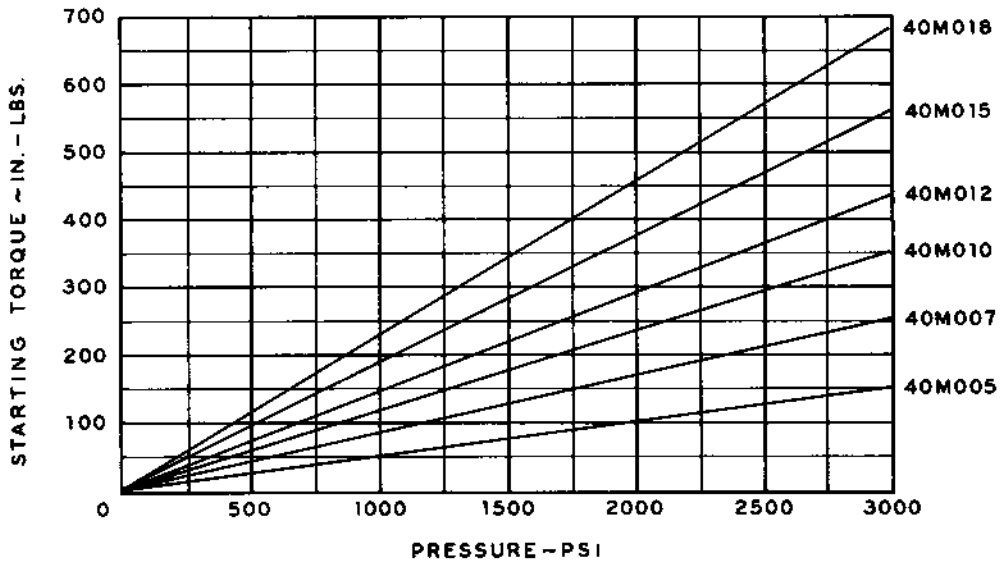

**VOLUMETRIC EFFICIENCY (%) vs. RPM
(TYPICAL)**

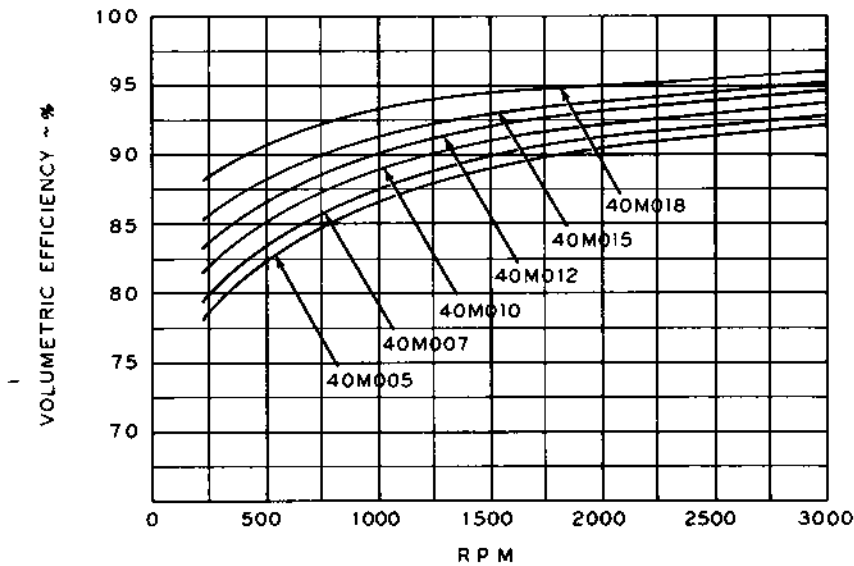

(FOR SPECIFIC PERFORMANCE DATA,
CONTACT CROSS ENGINEERING)

