

8

7

6

5

4

3

2

1

REVISIONS				
ZONE	REV.	DESCRIPTION	DATE	APPROVED

D

D

C

C

B

B

A

A

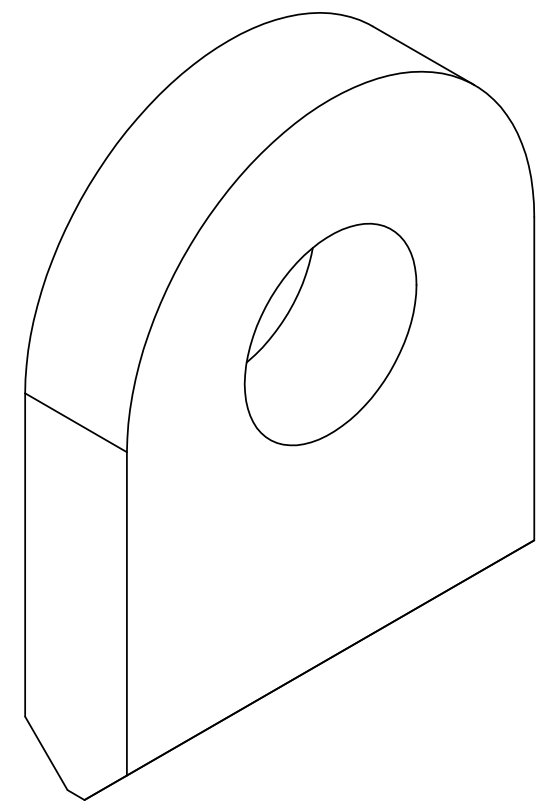
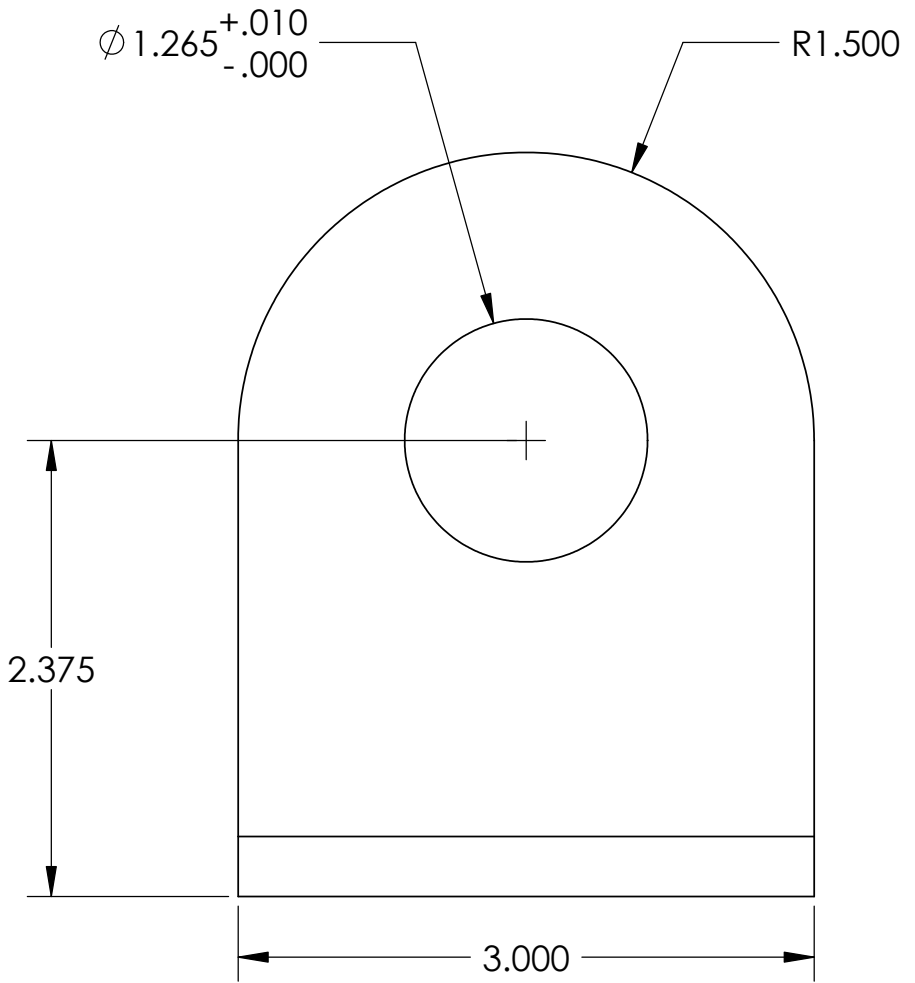
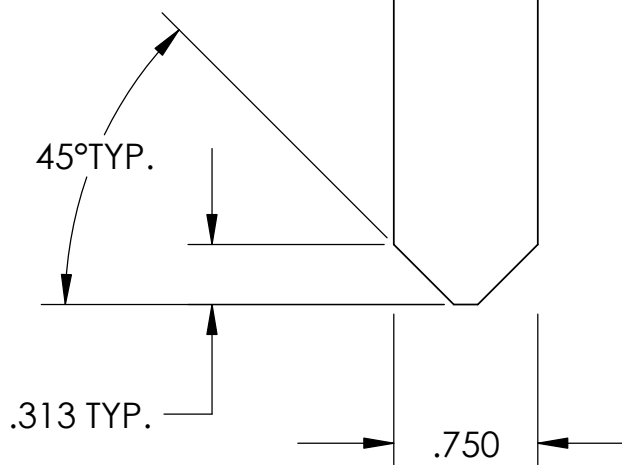

**PROPRIETARY AND CONFIDENTIAL**  
 THE INFORMATION CONTAINED IN THIS DRAWING IS THE SOLE PROPERTY OF KANAMAK HYDRAULICS, INC. ANY REPRODUCTION IN PART OR AS A WHOLE WITHOUT THE WRITTEN PERMISSION OF KANAMAK HYDRAULICS, INC IS PROHIBITED.

UNLESS OTHERWISE SPECIFIED:		DATE	NAME	KANAMAK HYDRAULICS, INC.
DIMENSIONS ARE IN INCHES		DRAWN	IDP	
TOLERANCES:		CHECKED		
FRACTIONAL ±		ENG APPR.		
ANGULAR: MACH ± BEND ±		MFG APPR.		TITLE: CLEVIS
TWO PLACE DECIMAL ± .06		Q.A.		
THREE PLACE DECIMAL ± .03		COMMENTS:		
INTERPRET GEOMETRIC TOLERANCING PER:				SIZE
MATERIAL <b>ASTM A36</b>				DWG. NO.
FINISH <b>HRS - MT</b>				REV
NEXT ASSY	USED ON			SCALE: 1:1
APPLICATION				WEIGHT:
				SHEET 1 OF 1

8

7

6

5

4

3

2

1