



**DIPLOMATIC
HYDRAULICS**

41 230/102 AD



MD1JB

SOLENOID OPERATED DIRECTIONAL CONTROL VALVES

**ALTERNATING CURRENT
SERIES 10**

NFPA D03 (CETOP 03)

p max 5,000 psi

Q max 18 GPM

MOUNTING INTERFACE

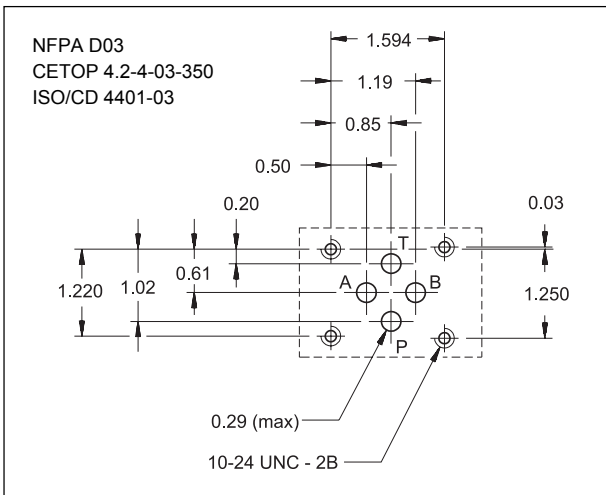

OPERATING PRINCIPLE

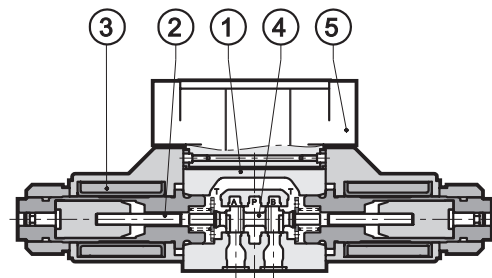

- Direct acting, subplate mounting directional control valve, with mounting surface according to NFPA D03 standard.

- The valve body ① is made with high strength iron castings provided with wide internal passages in order to minimize the flow pressure drop. Wet armature solenoids ② with easily removable interchangeable coils ③ are used (for further information on solenoids see par. 7). It is supplied with junction box ⑤ for the electrical connection.

- The valve is supplied with 3 or 4 way designs and with several interchangeable spools ④ with different porting arrangements.

-The valve is available with AC solenoids.

PERFORMANCE RATINGS (with mineral oil of viscosity of 36 cSt at 50°C)

Maximum operating pressure P - A - B ports	psi	5,000
T port		2,000
Maximum flow rate	GPM	18
Pressure drop $\Delta p-Q$	see par. 4	
Operating limits	see par. 6	
Electrical features	see par. 7	
Electrical connections	junction box	
Ambient temperature range	°F	-5 to +120
Fluid temperature range	°F	-5 to +180
Fluid viscosity range	SSU	65 to 1850
Recommended viscosity	SSU	125
Fluid contamination degree	according to NAS 1638 class 10	
Mass:		
single solenoid valve	lbs	4.4
double solenoid valve	lbs	3.3



MD1JB

SERIES 10

1 - IDENTIFICATION CODE

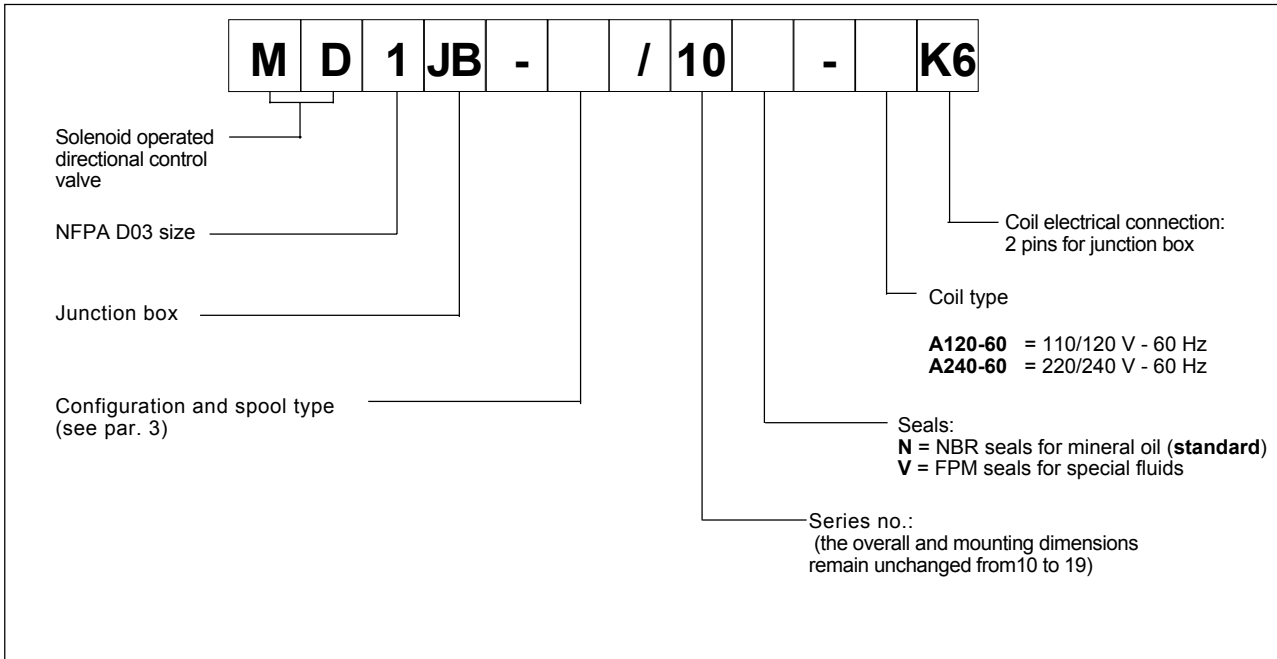

2 - HYDRAULIC FLUIDS

Use mineral oil-based hydraulic fluids, with the addition of suitable anti-frothing and anti-oxidising agents. For the use of other fluid types (water glycol, phosphate esters and others), please consult our technical department.

Using fluids at temperatures higher than 160°F causes a faster degrading of the fluid's characteristics and of the seals. The fluid must be preserved in its physical and chemical characteristics.



3 - CONFIGURATIONS

Type S:
3 positions with spring centering

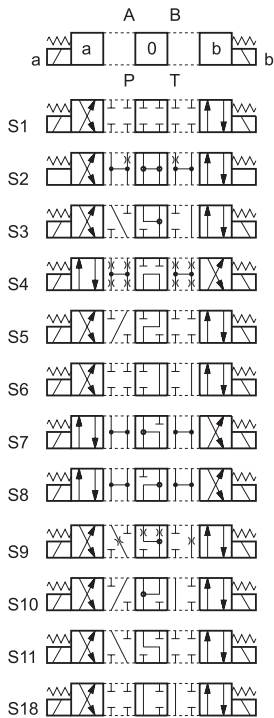

Type *TA:
2 positions with return spring

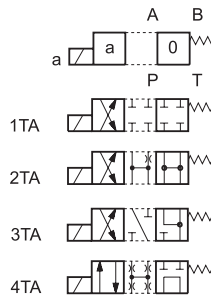

Type *TC:
2 positions with return spring

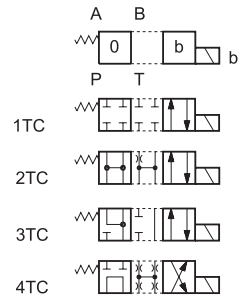

Type TA:
2 positions with return spring

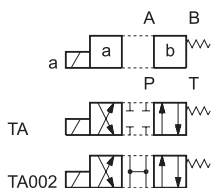

Type TC:
2 positions with return spring

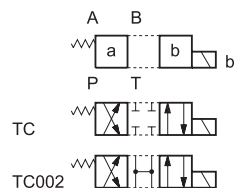

Type RK:
2 positions with mechanical retention

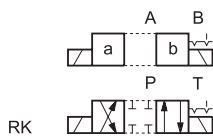

Model 32TA/32TC:
3-way valve - 1 solenoid - 2 external position, return spring

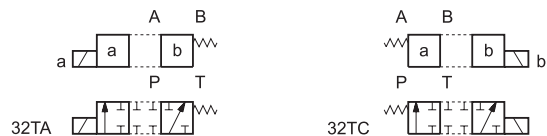

Besides the diagrams shown, which are the most frequently used, other special versions are available: consult our technical department for their identification, feasibility and operating limits.



MD1JB

SERIES 10

4 - PRESSURE DROP Δp -Q (obtained with viscosity of 170 SSU at 120°F)

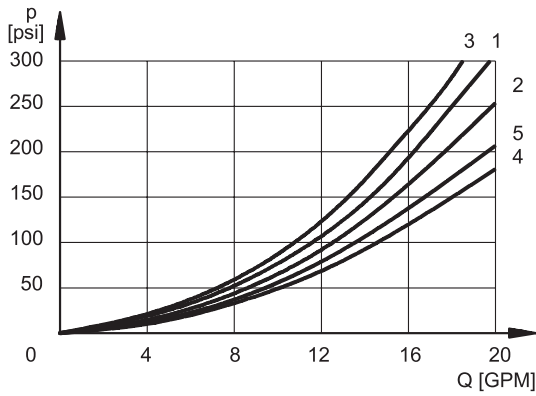

PRESSURE DROPS WITH VALVE ENERGIZED

SPOOL TYPE	FLOW DIRECTION			
	P-A	P-B	A-T	B-T
	CURVES ON GRAPH			
S1, 1TA, 1TC	1	1	2	2
S2, 2TA, 2TC	5	5	4	4
S3, 3TA, 3TC	1	1	4	4
S4, 4TA, 4TC	6	6	7	7
S5	1	5	2	2
S6	1	1	2	4
S7	5	6	7	7
S8	6	5	7	7
S9	1	1	2	2
S10	5	5	2	2
S11	1	1	4	2
S18	5	1	2	2
TA, TB	1	1	2	2
TA02, TB 02	1	1	2	2
32TA, 32TC	3	3		
RK	1	1	2	2

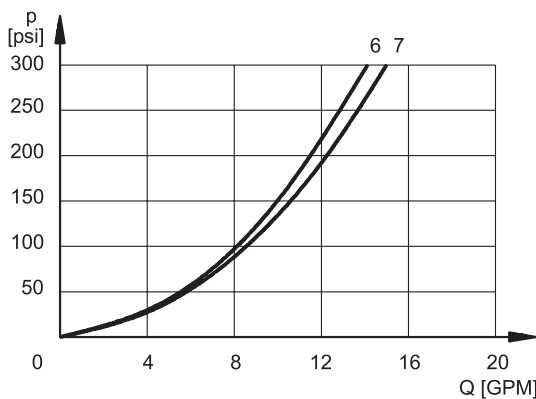

PRESSURE DROPS WITH VALVE IN DE-ENERGIZED POSITION

SPOOL TYPE	FLOW DIRECTION				
	P-A	P-B	A-T	B-T	P-T
	CURVES ON GRAPH				
S2, SA2, SB2					3*
S3, SA3, SB3			7 [■]	7 [○]	
S4, SA4, SB4					7
S5		7			
S6				7	
S7					7 [○]
S8					7 [■]
S9					
S10	7 [■]	7 [○]			
S11			7		
S18	7				

* A-B blocked ■ B blocked ○ A blocked

5 - SWITCHING TIMES

The values indicated refer to an S1 solenoid valve for Q=13 GPM, p=2,000 psi working with mineral oil at a temperature of 120 °F, a viscosity of 170 SSU and with PA and BT connections. The energizing times are obtained at the time the spool switches over. The de-energizing times are measured at the time pressure variation occurs on the line.

TIMES (±10%)	ENERGIZING	DE-ENERGIZING
AC solenoid	10 ÷ 25 ms	20 ÷ 40 ms



6 - OPERATING LIMITS

The curves define the flow rate operating fields according to the solenoid valve pressure with AC solenoids.

The values have been obtained with viscosity 170 SSU, temperature 120 °F, filtration 25 µm and with solenoids at rated temperature and supplied with voltage equal to 90% of the nominal voltage.

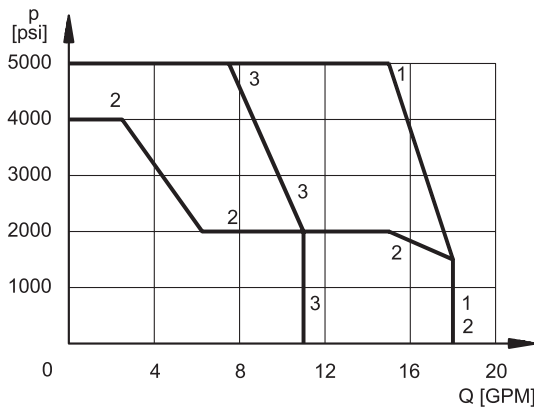

SPOOL TYPE	CURVE	
	P-A	P-B
S1,1TA,1TC	1	1
S2, 2TA, 2TC	1	1
S3, 3TA, 3TC	2	2
S4, 4TA, 4TC	3	3
S5	1	1
S6	2	2
S7	3	3
S8	3	3

SPOOL TYPE	CURVE	
	P-A	P-B
S9	3	3
S10	1	1
S11	2	2
S18	1	1
TA, TC	1	1
TA02, TB02	1	1
32TA, 32TB	1	1
RK	1	1

The values indicated in the two graphs can be considerably reduced if a 4-way valve is used with port A or B plugged.
For valves having supply voltage of 120V-60Hz or 240V-60Hz performances may be slightly higher than the ones showed in the diagram.



7 - ELECTRICAL FEATURES

7.1 Solenoids

These are essentially made up of two parts: tube and coil. The tube is threaded onto the valve body and includes the armature that moves immersed in oil, without wear. The inner part, in contact with the oil in the return line, ensures heat dissipation. The coil is fastened to the tube by a threaded nut. The interchangeability of coils of different voltages is allowed.

SUPPLY VOLTAGE FLUCTUATION	± 10% Vnom
MAX. SWITCH ON FREQUENCY	10.000 ins/hr
DUTY CYCLE	100%
Class of protection according to IEC 144 Atmospheric agents Coil insulation Impregnation	IP 65 class H class F

7.2 Current and absorbed power

In alternating current energizing, an initial phase (maximum movement) is seen, during which the solenoid consumes elevated value currents (inrush current); the current values diminish during the plunger stroke until it reaches the minimum values (holding current) when the plunger reaches the stroke end.

Coils (values ± 5%)

Type of coil	Frequency [Hz]	Nominal voltage [V]	Resistance at 20°C [ohm]	Current consumption at inrush [A]	Current consumption at holding [A]	Power consumption at inrush [VA]	Power consumption at holding [VA]	Code
C20.6-A120-60K6/10	60	110	27,5	1,8	0,36	198	39,6	1902820
		120		2	0,43	240	51,6	
C20.6-A240-60K6/10		220	110	0,86	0,17	189,2	37,4	1902821
		240		0,98	0,2	235,2	48	

8 - INSTALLATION

Configurations with centering and return springs can be mounted in any position; type RK valves - without a spring and with mechanical retention - must be mounted with the longitudinal axis horizontal. Valve fitting takes place by means of screws or tie rods, laying the valve on a lapped surface, with values of planarity and smoothness that are equal to or better than those indicated in the drawing. If the minimum values of planarity or smoothness are not met, fluid leakages between valve and mounting surface can easily occur. For use in tropical climates, it is necessary to include the CM option.

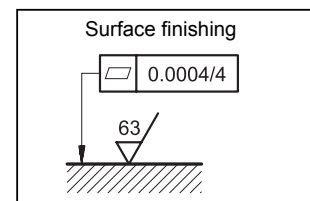



9 - OVERALL AND MOUNTING DIMENSIONS

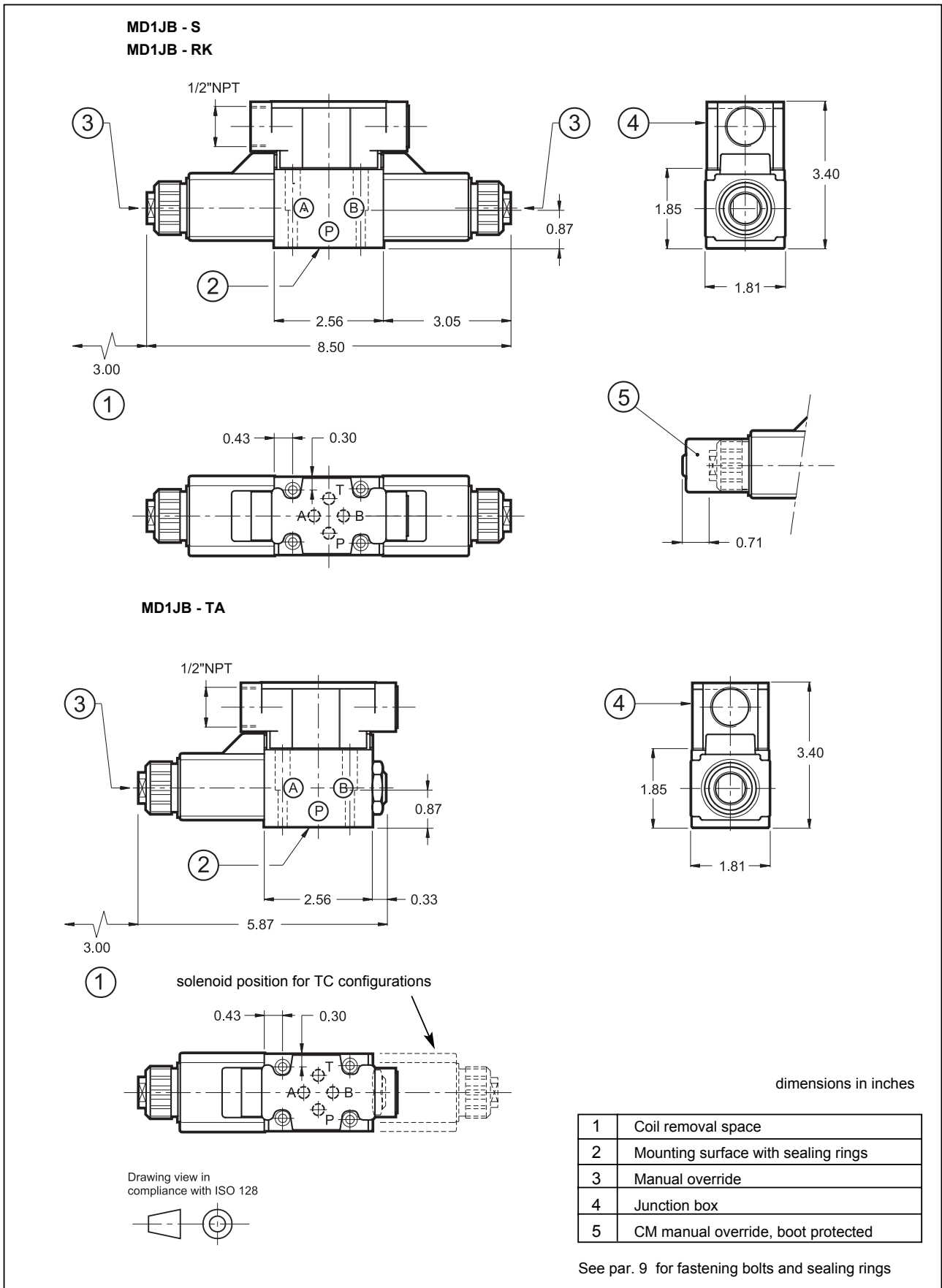



MD1JB

SERIES 10

10 - SPARE PARTS

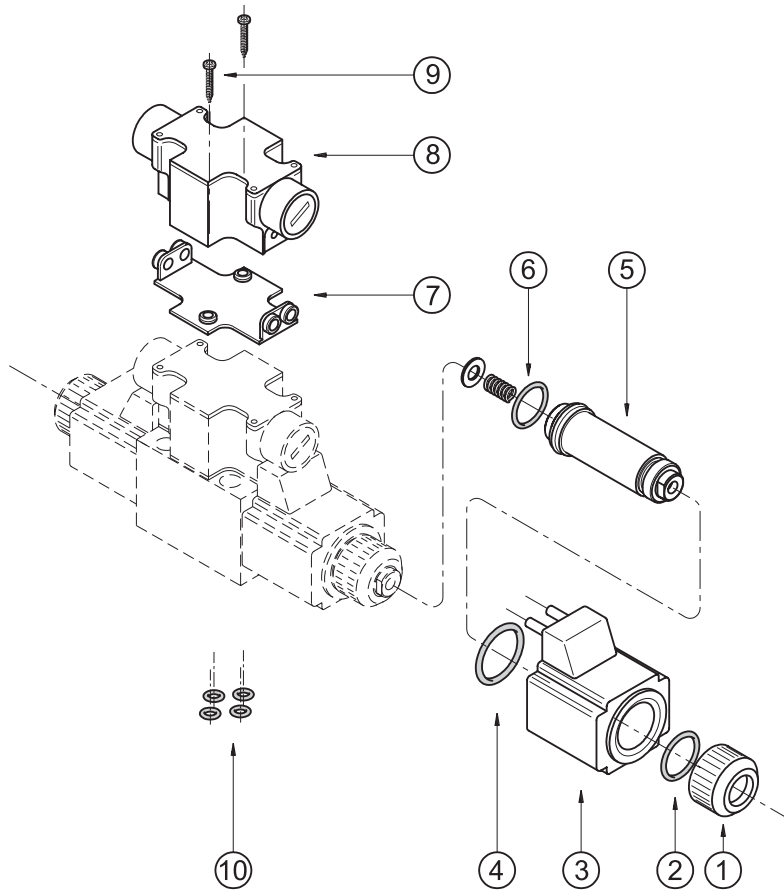

①	Coil locking ring cod. 0119333
②	O-Ring type 2-019 (2081) - 70 shore
③	Coil (see identification code on the side)
④	2 O-Ring type 3-910 - 70 shore
⑤	Solenoid tubes TA20.6-M18/10N (NBR seals) TA20.6-M18/10V (FPM seals) Note: the tube is supplied with O-Ring rif. ⑦
⑥	O-Ring type 2-016 (2062) - 70 shore
⑦	Seal for junction box cod. 0119407
⑧	Junction box EJB3-D/10 (double solenoid valve) EJB3-SA/10 (single solenoid valve MD1JB-TA/10) EJB3-SB/10 (single solenoid valve MD1JB-TC/10)
⑨	2 bolts M3x25
⑩	4 O-Ring type 2-012 (2037) - 90 shore

COILS IDENTIFICATION CODE

C 20.6 - K6 / 10

Supply voltage

A120-60 = 110/120 V - 60 Hz
A240-60 = 220/240 V - 60 Hz

Series no.: (the overall and mounting dimensions remain unchanged from 10 to 19)

Coil electrical connection: 2 pins for junction box

SEALS KIT

The codes herebelow include O-Rings ref. ② ④ ⑥ ⑩

Cod. 1985408 NBR seals
Cod. 1985409 FPM (viton) seals

11 - FASTENING BOLTS

4 bolts type 10-24 UNC - 2Bx2
Tightening torque 53 lbs·inch

 DIPLOMATIC HYDRAULICS	DIPLOMATIC OLEODINAMICA SpA 20025 LEGNANO (MI) - P.le Bozzi, 1 / Via Edison Tel. 0331/472111-472236 - Fax 0331/548328	UHI UNIVERSAL HYDRAULICS INT'L LTD 9337 Ravenna Road, Unit G, TWINSBURG, OHIO 44087 Phone +330-405-1800 - Fax +330-405-1801 E-mail: diplomatic@uhiltd.com
----------------------------------	--	--