

"COMPO CARE" - Pressure filters

PB



TECHNICAL DATA

ORDERING AND OPTIONS CHART

CLOGGING INDICATORS

PRESSURE DROP (Δp) CURVES

PRESSURE DROP (Δp) CURVES - MEDIA H+

REVERSE FLOW VALVE

CROSS FUNCTIONAL VIEW

SPARE PARTS ORDERING INFORMATION

DIMENSIONS OF THE FILTER ELEMENT

PB

COMPATIBILITY

Full with fluids: HH-HL-HM-HR-HV-HG (according to ISO 6743/4). For fluids different than the above mentioned, please contact our sales Department.

PRESSURE

Max. working 6,000 psi (420 bar)
 Test 9,000 psi (620 bar)
 Bursting 18,250 psi (1.260 bar)
 Collapse, differential for the filter element Series standard 300 psi (20 bar)
 serie H+ 3,000 psi (210 bar)

BYPASS VALVE

Setting 90 psi (6 bar) +/-10%

WORKING TEMPERATURE

from -15° to +230° F

MATERIALS

Head	Cast iron
Bowl	Steel
Bypass valve	Steel
Seals	Nitrile (NBR) (Viton® FPM on request)
Indicator housing	Brass

FPB 1

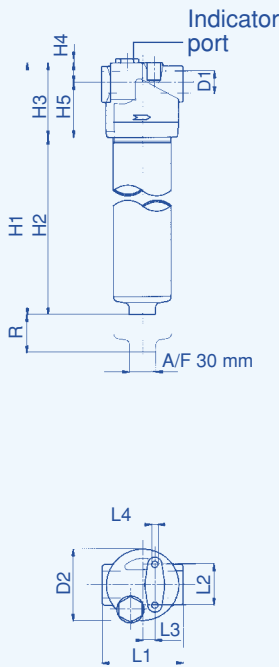

FPB 2

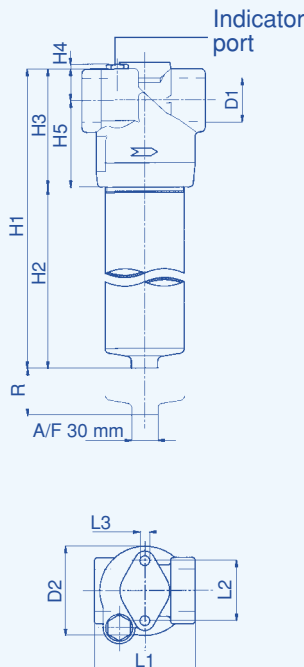

FPB 3

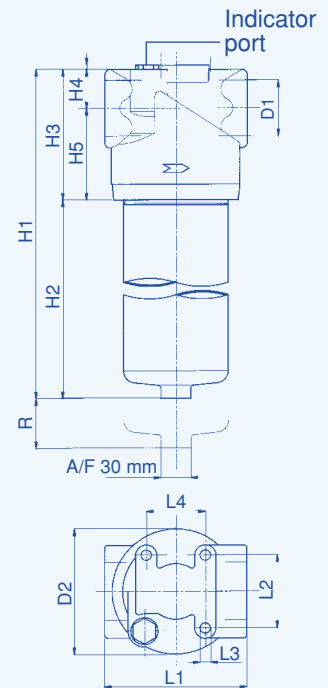

	D1	D2	H1	H2	H3	H4	H5	L1	L2	L3	L4	R	Weight lbs	
F PB11	3/4"	3.23	6.50	3.11	3.39	0.91	2.48	3.35	1.81	18 UNC	0.49	3.94	9.3	
F PB12	3/4"	3.23	7.68	4.29	3.39	0.91	2.48	3.35	1.81		0.49	3.94	9.7	
F PB13	3/4"	3.23	11.61	8.23	3.39	0.91	2.48	3.35	1.81		=	3.94	11.0	
F PB21	3/4" - 1"	3.70	8.90	4.57	4.33	1.38	3.03	4.21	2.56		=	3.94	13.9	
F PB22	3/4" - 1"	3.70	12.48	8.15	4.33	1.38	3.03	4.21	2.56		=	3.94	17.3	
F PB31	1" - 1 1/4" - 1 1/2"	5.04	9.61	4.21	5.39	1.73	3.66	5.63	3.46	14 UNC	1.69	3.94	23.2	
F PB32	1" - 1 1/4" - 1 1/2"	5.04	13.23	7.83	5.39	1.73	3.66	5.63	3.46		7/16"	1.69	3.94	29.4
F PB33	1" - 1 1/4" - 1 1/2"	5.04	17.95	12.56	5.39	1.73	3.66	5.63	3.46		1.69	3.94	36.4	
F PB34	1" - 1 1/4" - 1 1/2"	5.04	21.93	16.54	5.39	1.73	3.66	5.63	3.46		1.69	3.94	46.5	

ORDERING AND OPTIONS CHART

F FILTER COMPLETE												ELEMENT		E			
P	B	FAMILY, SIZE & LENGTH										FAMILY SIZE & LENGTH		P	B		
		11	12	13	21	22	31	32	33	34							
PORT TYPE																	
B = BSP - thread		B	B	B	B	B	B	B	B	B	B	B	B	B	B	B	
N = NPT - thread		N	N	N	N	N	N	N	N	N	N	N	N	N	N	N	
S = SAE - thread		S	S	S	S	S	S	S	S	S	S	S	S	S	S	S	
D = SAE Flange 3000 psi		=	=	=	D	D	D	D	D	D	D	D	D	D	D	D	
E = SAE Flange 6000 psi		=	=	=	E	E	E	E	E	E	E	E	E	E	E	E	
PORT SIZE																	
06 = 3/4" (F06 not available)		06	06	06	06	06	=	=	=	=	=	=	=	=	=	=	
08 = 1" (F08 available for PB 21-22 only)		=	=	=	08	08	08	08	08	08	08	08	08	08	08	08	
10 = 1 1/4"		=	=	=	=	=	10	10	10	10	10	10	10	10	10	10	
12 = 1 1/2" (G12 option not available)		=	=	=	=	=	12	12	12	12	12	12	12	12	12	12	
BYPASS VALVE																	
W = without		W	W	W	W	W	W	W	W	W	W	W	W	W	W	W	
C = 90 psi (6 bar)		C	C	C	C	C	C	C	C	C	C	C	C	C	C	C	
R = reverse flow valve		=	=	=	R	R	R	R	R	R	R	R	R	R	R	R	
P = reverse flow + bypass valve		=	=	=	P	P	P	P	P	P	P	P	P	P	P	P	
SEALS												SEALS					
N = nitrile NBR		N	N	N	N	N	N	N	N	N	N	N	N	N	N	N	N = NBR
F = Viton® FPM		F	F	F	F	F	F	F	F	F	F	F	F	F	F	F	F = FPM
FILTER MEDIA												FILTER MEDIA					
FA = fiber 3 μ β>200, Δp 20 bar		FA	FA	FA	FA	FA	FA	FA	FA	FA	FA	FA	FA	FA	FA	FA	FA=fib. 3 μ 20 bar
FB = fiber 6 μ β>200, Δp 20 bar		FB	FB	FB	FB	FB	FB	FB	FB	FB	FB	FB	FB	FB	FB	FB	FB=fib. 6 μ 20 bar
FC = fiber 12 μ β>200, Δp 20 bar		FC	FC	FC	FC	FC	FC	FC	FC	FC	FC	FC	FC	FC	FC	FC	FC=fib.12μ 20 bar
FD = fiber 25 μ β>200, Δp 20 bar		FD	FD	FD	FD	FD	FD	FD	FD	FD	FD	FD	FD	FD	FD	FD	FD=fib.25μ 20 bar
HA = fiber 3 μ β>200, Δp 210 bar		HA	HA	HA	HA	HA	HA	HA	HA	HA	HA	HA	HA	HA	HA	HA	HA=fib. 3 μ 210 bar
HB = fiber 6 μ β>200, Δp 210 bar		HB	HB	HB	HB	HB	HB	HB	HB	HB	HB	HB	HB	HB	HB	HB	HB=fib. 6 μ 210 bar
HC = fiber 12 μ β>200, Δp 210 bar		HC	HC	HC	HC	HC	HC	HC	HC	HC	HC	HC	HC	HC	HC	HC	HC=fib.12μ 210 bar
HD = fiber 25 μ β>200, Δp 210 bar		HD	HD	HD	HD	HD	HD	HD	HD	HD	HD	HD	HD	HD	HD	HD	HD=fib.25μ 210 bar
CC = cellulose 10 μ β>2, Δp 20 bar		CC	CC	CC	CC	CC	CC	CC	CC	CC	CC	CC	CC	CC	CC	CC	CC=cel.10μ 20 bar
CLOGGING INDICATORS																	
02 = port, plugged		02	02	02	02	02	02	02	02	02	02	02	02	02	02	02	02
K2 = differential, visual 75 psi (5 bar)		K2	K2	K2	K2	K2	K2	K2	K2	K2	K2	K2	K2	K2	K2	K2	K2
K3 = differential, visual 120 psi (8 bar)		K3	K3	K3	K3	K3	K3	K3	K3	K3	K3	K3	K3	K3	K3	K3	K3
Y2 = differ., visual-electrical 75 psi (5 bar)		Y2	Y2	Y2	Y2	Y2	Y2	Y2	Y2	Y2	Y2	Y2	Y2	Y2	Y2	Y2	Y2
Y3 = differ., visual-electrical 120 psi (8 bar)		Y3	Y3	Y3	Y3	Y3	Y3	Y3	Y3	Y3	Y3	Y3	Y3	Y3	Y3	Y3	Y3
X ACCESSORIES																	
X = no accessory available		X	X	X	X	X	X	X	X	X	X	X	X	X	X	X	X

CLOGGING INDICATORS

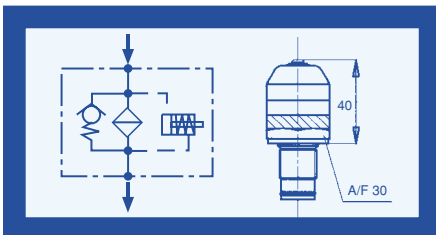

Series K2 & K3:
differential visual indicator,
set 75 psi (5 bar)- K2
& 120 psi (8 bar)- K3 +/-10%

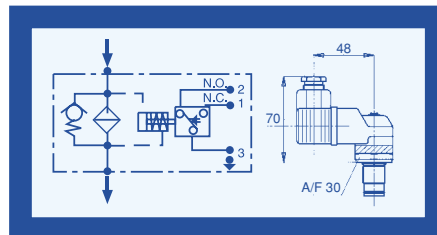

Series Y2 & Y3:
differential visual-electrical indicator,
set 75 psi (5 bar)-Y2 & 120 psi (8 bar)-Y3 +/-
10%.
Connector according to DIN 43650.
Protection IP65 according to DIN 40050.
SPDT:
C.A. 125-250 V
> max resistive or inductive load 1A;
C.C. 30-50-75-125 V
> max resistive load 2-0.5-0.25-0.2A resp.
> max inductive load 2-0.5-0.25-0.03A resp.

PRESSURE DROP (Δp) CURVES

The "Assembly Pressure Drop (Δp)" is obtained by adding the pressure drop values of the filter Housing and of the Clean Filter Element corresponding to the

considered Flow Rate and it must be lower than 12 psi (0.8 bar).

FILTER HOUSING PRESSURE DROP (mainly depending on the port size)

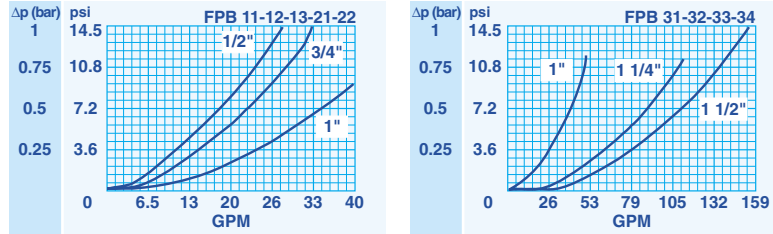

CLEAN FILTER ELEMENT PRESSURE DROP USING MEDIA F+ e C+

(depending both on the internal diameter of the element and on the filter media)

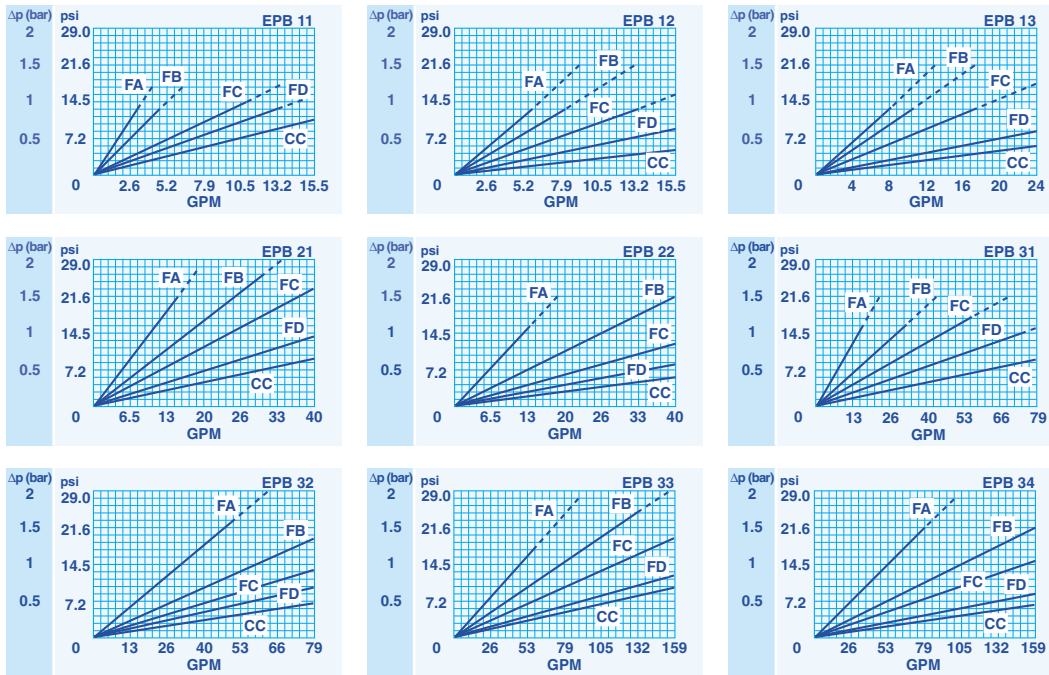

BYPASS VALVE PRESSURE DROP

When selecting the filter size, these curves must be taken into account if it is foreseen that any flow peak is to be absorbed by the bypass valve, it also must

be of proper configuration to avoid pressure peaks. The valve pressure drop is directly proportional to fluid specific gravity.

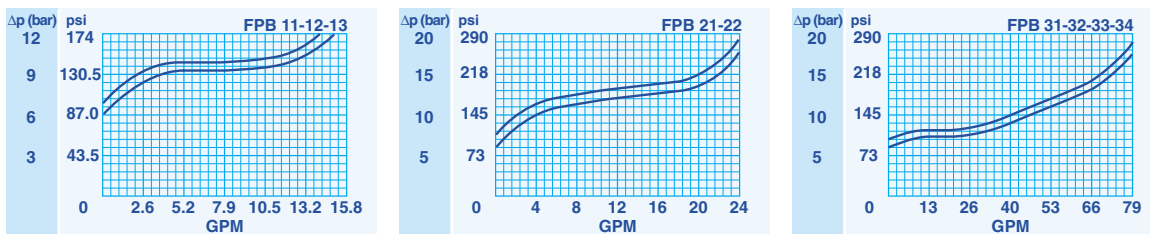

PRESSURE DROP (Δp) CURVES

The "Assembly Pressure Drop (Δp)" is obtained by adding the pressure drop values of the filter Housing and of the Clean Filter Element corresponding to the

considered Flow Rate and it must be lower than 12 psi (0.8 bar).

CLEAN FILTER ELEMENT PRESSURE DROP (depending both on the internal diameter of the element and on the filter media)

MEDIA H+ (recommended with no bypass option)

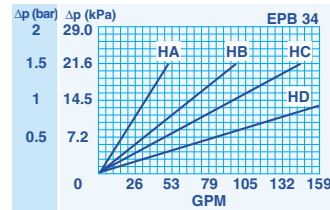
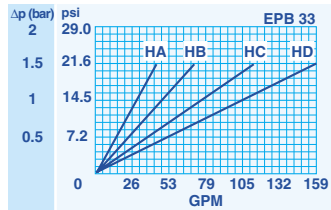
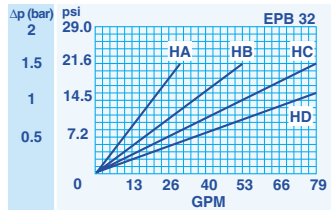
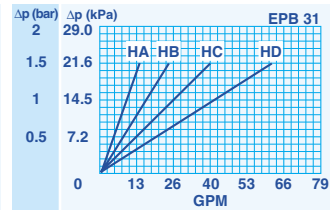
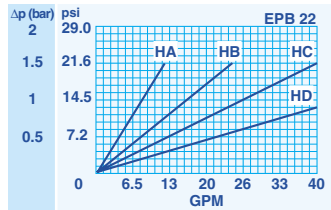
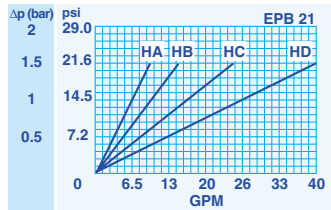
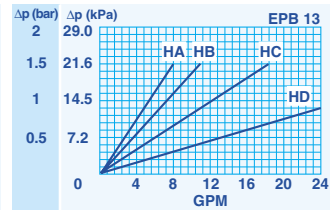
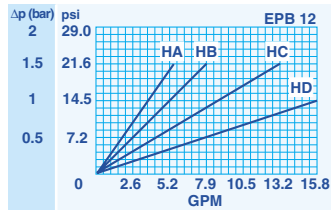
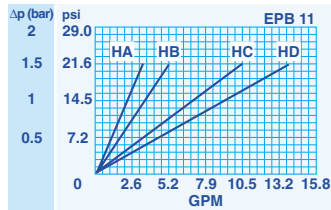

N.B.
All the curves have been obtained with mineral oil having a kinematic viscosity 30 cSt and specific gravity 0.9; for fluids with different features, please consider the factors described in the first part of this catalogue.

N.B. All the curves are obtained from test done at the UFI HYDRAULIC DIVISION Laboratory, according to the specification ISO 3968. In case of discrepancy, please check the contamination level, viscosity and features of the fluid in use.

REVERSE FLOW VALVE

For hydraulic systems where reverse flow can occur, the pressure filters series FPB2+ and FPB3+ are available with a free reverse flow valve allowing the fluid to pass through the filter element in the normal direction and to bypass the filter element in the reverse

direction (option "R"). The reverse flow valve is available also with incorporated bypass valve for the normal flow direction, set at 6 bar (option "P").

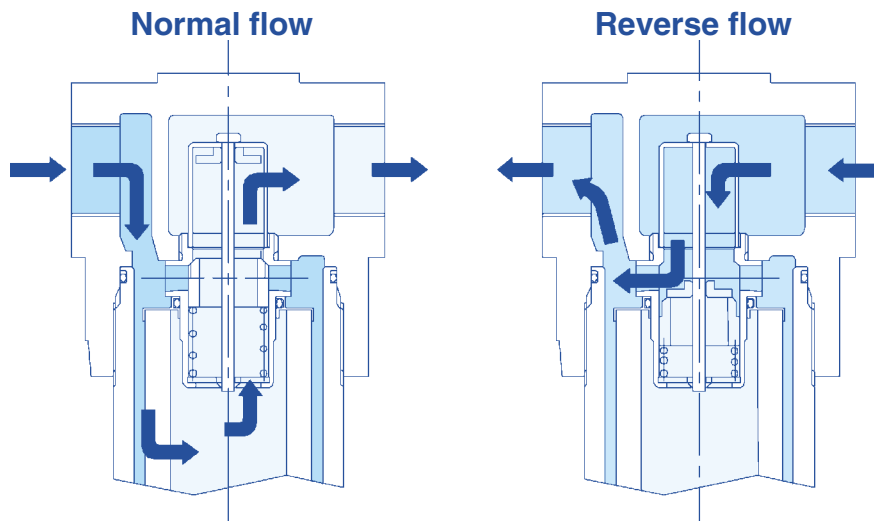

In normal flow conditions the whole flow pass through the filter element. In the option "P", if the differential pressure across the element exceeds 6 bar the bypass is activated. For the pressure drop through the bypass valve, please see our catalogue COMPO CARE - series PB. In reverse flow conditions the flow bypasses the filter element.

Pressure drop through the valve in the reverse direction:
6 psi at 26 GPM
9 psi at 53 GPM
12 psi at 79 GPM

CROSS FUNCTIONAL VIEW

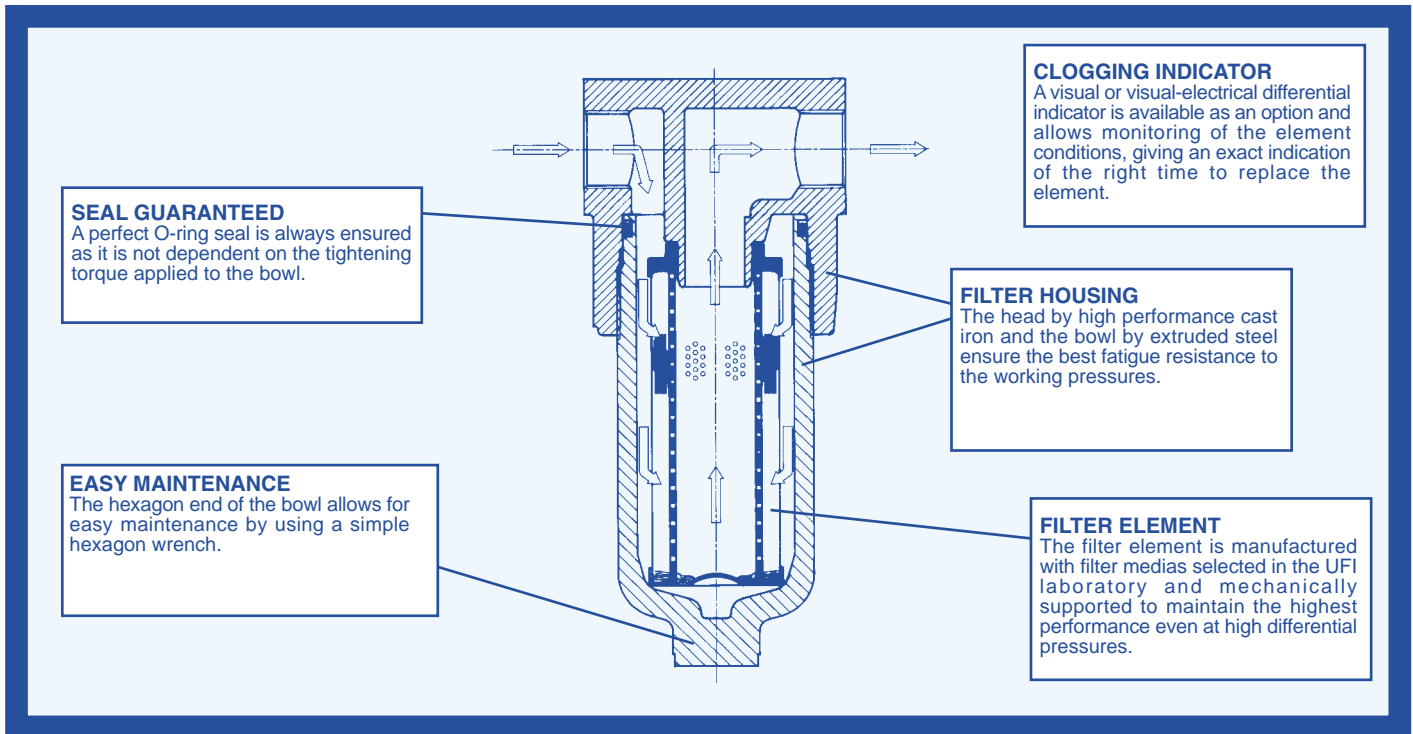

SPARE PARTS ORDERING INFORMATION

(from the code of the complete filter, fill the digits corresponding to the boxes)

Filter housing	B	P	B	<input type="checkbox"/>	<input type="checkbox"/>	<input type="checkbox"/>	<input type="checkbox"/>	<input type="checkbox"/>	<input type="checkbox"/>	<input type="checkbox"/>	X	X	<input type="checkbox"/>	<input type="checkbox"/>	X
Head	S	P	B	<input type="checkbox"/>	X	<input type="checkbox"/>	<input type="checkbox"/>	<input type="checkbox"/>	X	<input type="checkbox"/>	X	X	X	X	X
Bowl	S	P	B	<input type="checkbox"/>	<input type="checkbox"/>	X	X	X	X	<input type="checkbox"/>	X	X	X	X	X
Seal kit	S	P	B	<input type="checkbox"/>	X	X	X	X	X	<input type="checkbox"/>	X	X	X	X	X

DIMENSIONS OF THE FILTER ELEMENT

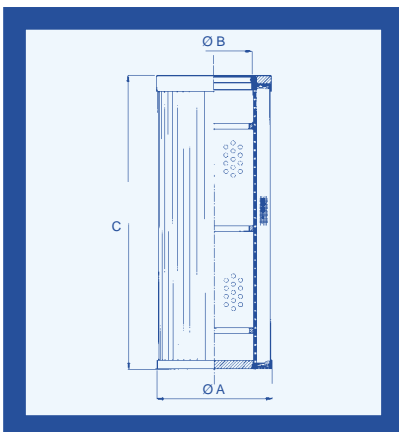

Type	A	B	C	Area (in ²)	
				Media F+	Media C+
EPB 11	1.77	0.98	3.35	55.0	48.1
EPB 12	1.77	0.98	4.57	77.5	67.4
EPB 13	1.77	0.98	8.31	144.9	126.3
EPB 21	2.05	0.93	4.53	151.1	120.9
EPB 22	2.05	0.93	8.27	283.7	227.1
EPB 31	3.07	1.67	4.65	310.0	266.6
EPB 32	3.07	1.67	8.27	572.7	491.4
EPB 33	3.07	1.67	12.99	778.9	623.9
EPB 34	3.07	1.67	16.93	1,020.7	1,020.7

UFI Universal Filter International - Hydraulic Division: 9337 Ravenna Road, Unit G - Twinsburg, OH 44087
Phone (330) 4051800 - Fax (330) 4051801 - E-mail: sales@uhilt.com

UFI HYDRAULIC DIVISION - PLANET FILTERS S.p.A.
via S.Chierico, 24 - 24060 Bolgare BG - Tel. 035 4493831 - Fax 035 843743
e-mail: info@planetfilters.it - http://www.ufifilter.com

COMPANY
WITH QUALITY SYSTEM
CERTIFIED BY DNV
= ISO 9001/2000 =

COMPANY WITH
ENVIRONMENTAL MANAGEMENT
SYSTEM CERTIFIED BY DNV
= ISO 14001 =